



DELTA

**VRF ENERGY RECOVERY VENTILATION SYSTEM
80RV SERIES**

INSTRUCTION MANUAL

WARNING!

Read and follow all safety precautions in Instruction Manual - improper use can cause serious injury.

Contents

| | |
|--|----|
| 1 Preface | 1 |
| 2 Introduction to Products..... | 1 |
| 3 Wired Controller (Standard fitting)..... | 3 |
| 4 Outline and Dimension | 8 |
| 5 Equipment Installation | 9 |
| 6 Electric Project..... | 14 |
| 7 Electric Installatrion | 15 |
| 8 Operation and Maintenance | 16 |
| 9 Notice for Safety | 17 |

1 Preface

Our living environments are more and more affected by modern civilization. As the application of air-conditioning system and various composite materials, popularization of office equipments and development of closeness of constructions and for the purpose of energy saving and reduction of cost which cause decrease of fresh air volume, harmful gas and pollution of creature won't be diluted properly and replaced. Healthy, energy-saving, simple and reliable fresh-air system and equipment has been the focus for engineers and users. DELTA energy recovery ventilation system has solved this problem. This kind of system has two-way air exchange function so that the change of indoor temp is little during air exchange. The indoor air can be efficiently filtered by the air filter. New technology and materials and special technique applied in the unit can ensure low energy consumption, great performance, low noise and easy installation.

2 Introduction to Products

2.1 Main Features

(1) Replacement and Ventilation Function

It introduces fresh air into room and discharges indoor air out of room to make you feel comfortable as in the nature.

(2) Energy-recovery Function

Internal heat exchanger makes the discharged air and introduced air for cooling and heating exchange. Energy-recovery rate above 70% makes heat insulating ventilation realized.

(3) Low-noise Design

Special low-noise ventilation fan is set.

(4) Air Filtration and Purge Function

Internal air filter keeps the fresh air introduced into room pure and dustless.

(5) Various Series and Multiple Specifications

There are various series to match with the buildings of various structures.

2.2 Features of Structure

DELTA energy-recovery ventilation system consists of main unit, electric control system and so on.

2.3 Main Unit

Some parts like low-noise centrifugal fan, heat exchanger and so on are set in the main unit. The air can be filtered effectively against dust particles, fibre etc. before entering into heat exchanger. The filter in the unit can be taken out after opening the service door. The bonded place between case and service door is sealed with long-acting sealing materials to prevent leakage of case. The case is made of cold-rolled plate and its double sides are sprayed with plastic for anticorrosion. The inner side of case is adhered with rubber and plastic foaming material which can effectively absorb the noise from running of ventilation fan and prevent radiation of case.

Fig.1 is the sketch of main structure (service door has been taken out).

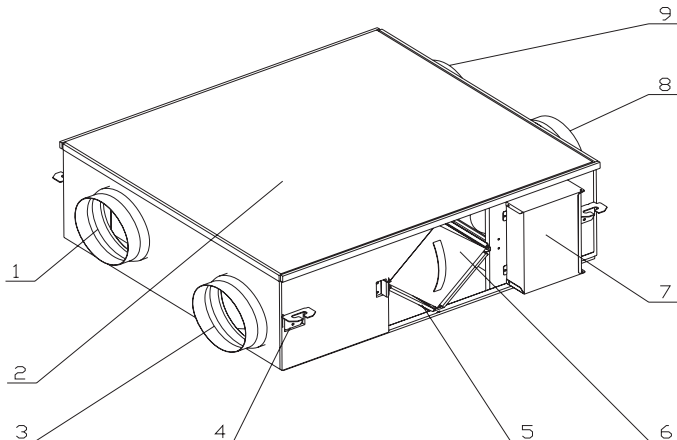

1—Room air outlet 2—Case 3—Fresh air inlet 4—Lifting lug 5— Air filter
6—Heat exchanger 7—Electric box 8—Fresh air outlet 9—Room air inlet

Fig.1 80RV series energy recovery ventilation system (standard)

3 Wired Controller (Standard fitting)

3.1 Instruction to Wired Controller



Notice!

- Never install it in the place with water leakage.
- Never knock, drop or frequently turn on/off it.

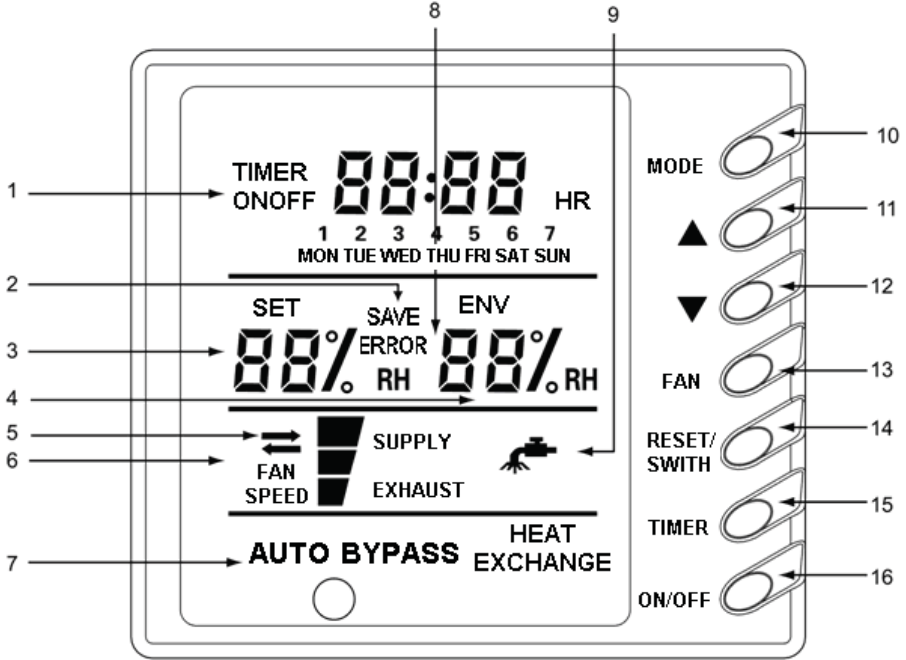

Fig. 2 Front panel of wired controller

| Constitution of wired controller | | | |
|----------------------------------|--|----|----------------------------------|
| 1 | Timer display | 10 | Mode button |
| 2 | Energy-saving status display | 11 | Setting humidity increase button |
| 3 | Setting humidity display | 12 | Setting humidity decrease button |
| 4 | Ambient humidity display | 13 | Fan speed button |
| 5 | Air exchange mode (half-half air exchange, discharge and supply) | 14 | Reset/Switch button |
| 6 | Fan speed display (high, mid, low) * | 15 | Timer button |
| 7 | Mode(auto, by-pass, heat exchange) | 16 | On/Off button |
| 8 | Error status display | | |
| 9 | Cleaning status of filter display | | |

Note: for the units 80RV090N20 and 80RV120N20, air discharge and air supply listed in the No. 5 are unavailable, and air speed listed in No. 6 is unchangeable.

3.1.1 Turn On / Off the Unit

- (1) Press ON/OFF button to start the unit. (Fig.3)
- (2) Press ON/OFF button once again to stop the unit.

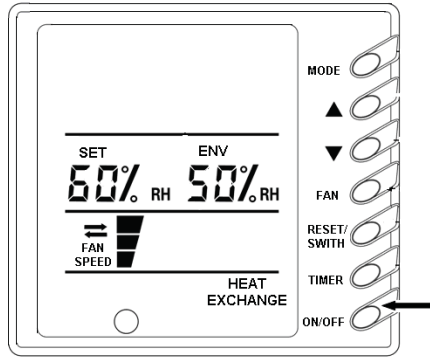

Fig.3

3.1.2 Fan Speed Control (Fig.4,5)(The figure is about relative display area, the same as below)

(1) During half-half air exchange, With each press of FAN button, the fan speed will change in the following order(Fig.4):

Note: Air speed is unchangeable for the units 80RV090N20.

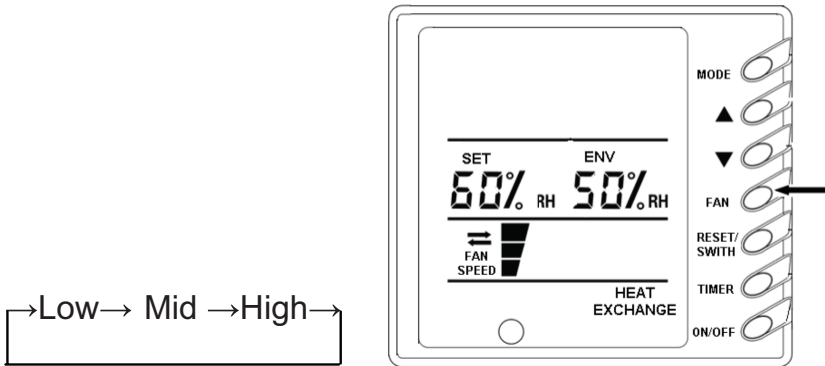

Fig.4

(2) During air discharge and air supply, with each press of FAN button, the fan speed will switch between high speed and low speed(Fig.5).

Note: Air speed is unchangeable for the units 80RV090N20.

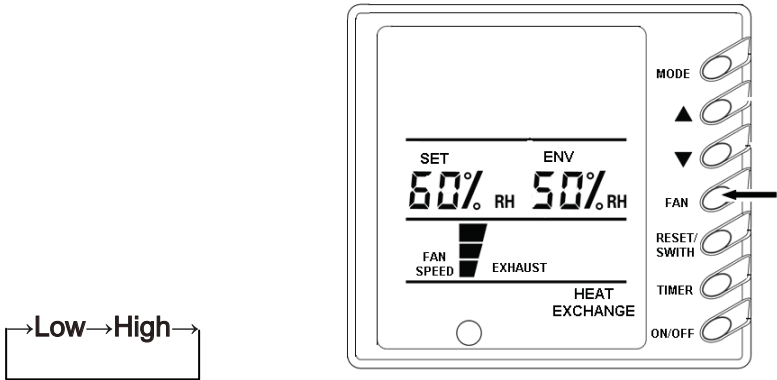

Fig.5

3.1.3 Humidity Adjustment (Fig.6)

If there is humidifying function in the unit, press humidify button:

▲: Used to increase setting humidity.

▼: Used to decrease setting humidity. Once press of this button, the temperature will increase or decrease by 5%.

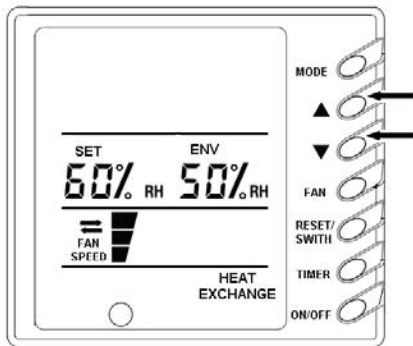

Fig.6

Note: Lock function: Pressing ▲ and ▼ simultaneously for 5s, the place of setting humidity will display EE and all response to the buttons Fig.6 will be shielded. And then press ▲ and ▼ simultaneously for 5s to release Lock Function.

When long-distance monitoring or centralized control shield displayed, the signals of buttons and from remote controller will be shielded, and CC will be displayed in the place of setting humidity.

Setting range of humidity: 40%~60%RH.

3.1.4 Reset/ Switch Function Setting

Not having pressed Timer button, long press Reset/ Switch button for 5s to clear operation time and icon.

After pressing of Timer button

Under On status of the unit:

Short press Reset/ Switch button to switch among Timer off setting, Energy saving startup setting, Energy saving stop setting and Clear time setting.

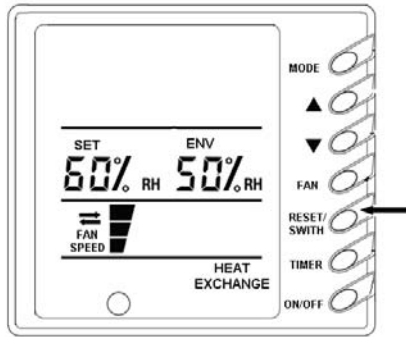
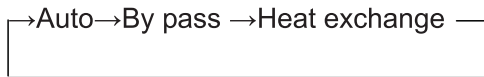

Fig.7

3.1.5 Running Mode Setting (Fig.8)

(1) Each press of this button, the operation mode will change as follow,



(2) Under Auto mode, the letter of Auto will light, so the system will operate according to temperature and temperature difference between room and outdoors.

(3) Under By pass mode, the letter of By Pass will light, so the fan will operate according to setting Fan mode and fan speed. Make this mode operate in transient season to prolong service life of the core of heat exchanger.

(4) Under Heat Exchange mode, the letter of Heat Exchange

will light. After shutdown of air valve, the fan will operate according to setting fan mode and fan speed. Under this mode, the total heat exchange of temperature and humidity can be realized along with exchange of fresh air, which is energy saving and healthy.

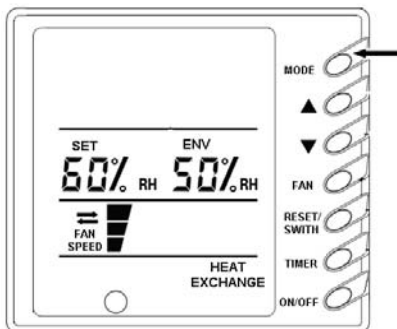

Fig.8

3.1.6 Timer Setting(Fig.9)

(1) In off status of the unit, timer on can be set and in on status, timer off, energy-saving on and energy –saving off and air clear can be set.

(2) Press Timer button into timer setting status. TIMER,Hr and letters corresponding setting will blink.

(3) (E.g. during timer off setting, Timer,Hr and OFFwill flash).In this case, the user can press ▲ or ▼to increase or decrease setting time. Repress Timer button to make the timer valid and the timing will be Fig.9 calculated after that. When the unit is under timer state, press theTimer button to cancel it. The time interval is 0.5 hr. The setting range of Timer on/off is 0.5-24hr.

(4) The setting range of Energy Saving On is 2-5hr and the default is 2hr.

(5) The setting range of Energy Saving Off is 1-4hr and the default is 1hr. (Note: press FAN and ▼ at the same time for 5s only after energy saving timer setting, the energy saving function can operate.

(6) The setting range of Timer Clear is 1250hr, 2500hr and 00000.The default is 1250hr.

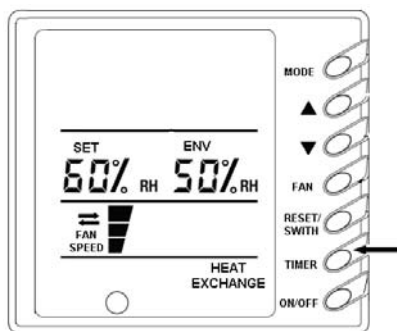

Fig.9

3.1.7 Ambient Temp Display

Under normal state, only indoor ambient humidity is display at ENV.

Notice: The humidifying function with the unit can be valid after it is started.

3.1.8 Humidifying ON/OFF Display

Press MODE and ▼at the same time for 5s to switch between humidifying ON/OFF.

Note:The unit with humidifying function can normally run. The indoor humidity and setting humidity can be displayed only If this function is on. The default is OFF. It is recommended to ON in dry period. The fittings are optional.

3.1.9 Fan Mode Display

Press FAN and ▲ at the same time for 5s to switch among half-half air exchange, discharge and supply. Refer to Fig.2 for details. The fan mode is selected by the users. E.g. plus pressure is needed in the room, fan mode can be adopted and if negative pressure is needed, air discharge mode can be adopted. Half-half air exchange is for normal station.

3.1.10 Energy Saving Mode Display

Press FAN and ▼ at the same time for 5s to switch between energy saving on/off. If under energy saving on state, Energy Saving will be displayed. Refer to Fig.2 for details. If the unit needn't operate for a long time, energy saving mode can be adopted to meet the demands of both function of fresh air exchange and quality of indoor air by users.

3.1.11 Fault Display

If fault happens during operation of the system, "ERROR" and error code will be displayed in the display. (Timer can not be displayed)

| Error Code | Error |
|------------|---|
| E6 | Communication error |
| F0 | Indoor temp sensor error |
| L1 | Humidity sensor error |
| | Outdoor temp sensor error |
| L0 | Air valve and relevant fitting error or wrong connection of centralized control wiring of air valve |

3.1.12 Intelligent On-off

Intelligent on-off which is applied in a unit to connect air valves in many rooms is also centralized control to air valve. A piece of pin board can be used to connect with up to 18 air valves. Many pieces of poniarded can also be used to connect with more air valves. The pin board is special fitting.

4 Outline and Dimension

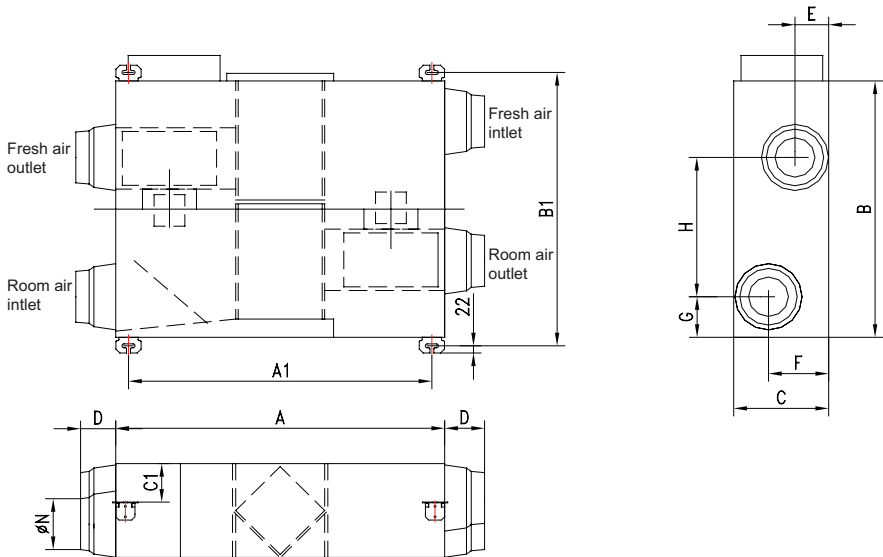

Fig. 10 Outline and Dimension

| Model | A | A1 | B | B1 | C | C1 | D | E | F | G | H | N |
|------------|------|------|------|------|-----|-----|-----|-----|-----|-----|-----|-----|
| 80RV030N20 | 879 | 823 | 800 | 852 | 306 | 125 | 90 | 125 | 175 | 136 | 416 | 197 |
| 80RV050N20 | 1016 | 960 | 832 | 884 | 380 | 165 | 90 | 150 | 230 | 155 | 372 | 246 |
| 80RV060N20 | 1016 | 960 | 832 | 884 | 380 | 165 | 90 | 150 | 230 | 155 | 372 | 246 |
| 80RV090N20 | 1215 | 1159 | 1210 | 1162 | 452 | 200 | 100 | 190 | 277 | 178 | 737 | 297 |

5 Equipment Installation

5.1 General Description

Models selection and project design should be performed by professional engineer of heating and ventilation. The project should be constructed by experienced construction organizations according to national criteria and rules. Once the unit can not operate normally for the user fails to conform to the requirements for installation, our company will charge the user for after-sales service.

5.2 Project Design

5.2.1 Main Points

This unit should be equipped with two ventilating ducts for two-way ventilation between room and outdoors. One duct is used to introduce fresh air into room and the other one is used to discharge indoor air out of room. The duct will resist the air flow which passes the duct. The greater the resistance is, the lower the ventilation quantity is, so long duct, small caliber, or big quantities of elbows will result in great resistance to the air in the duct and low ventilation quantity. Please perform design and installation according to the following principles:

(1) Neither of the ducts can exceed 15–30m long (according to models). Internal cross-sectional area of the duct is decided by internal fan speed, about 8m/s in main pipe and about 5m/s in branch pipe. If rectangular duct is used, the scale of length between two sides can not exceed. The duct should be made of noncombustible materials.

(2) Use elbows as few as possible, which should be within 3 for either duct. The bending part can never be 90° but arc, as shown in fig.11 and 12.

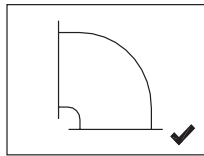
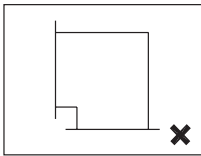

Fig.11 Elbow type

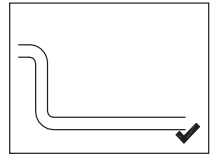
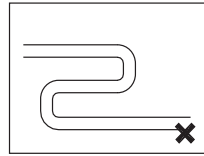

Fig.12 Arrangement of duct

(3) The inwall of the duct should be slick, dustless and unfolding.

(4) Keep air resistance of decorative vent on outdoor wall and indoor ceiling low. It is better to install rectangular aluminum alloy diffuser or two-layer louver with caliber of above 200×200mm. If the outdoor vent is waterproof louver, its caliber area should be 3-4 times bigger than cross-sectional area of duct connecting with it so that air flow can pass through the louver smoothly. The selection of outdoor vent is shown as fig.13.

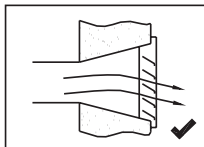
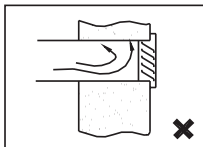

Fig.13 Outdoor vent

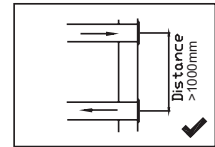
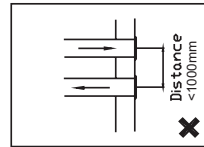

Fig.14 Distance between outdoor vents

(6) If the user intends to lower the indoor noise as much as possible, silencer can be concatenated in the duct and should be installed under the guidance of professionals. The noise at

vent of unit can usually be decreased by 4-6 dB after installation of suitable silencer.

(7) If electric heater is set in the duct, its switch should be interlocked with that of ventilation system, i.e. it only can start after ventilation fan start running. The duct within 800mm in the front or at the back of electric heater or the duct passing through the room where there is fire source should adopt incombustible materials for heat insulation.

(8) The air filter core should be replaced periodically, so maintenance space should be reserved at one side of fresh air ventilation system during installation.

(9) The steel hanger should be pre-built in the ceiling for cassette type ventilation system and its type and specification should accord to its weight to ensure firmness and reliability of installation. If the project is reconstructed, the hanger should be put after drilling holes in the ceiling, as shown in Fig.15 (a). If it is not convenient to drill holes, through chiseling the concrete, find out the inner steel bars which can hang the hanger as shown in fig.15 (b).

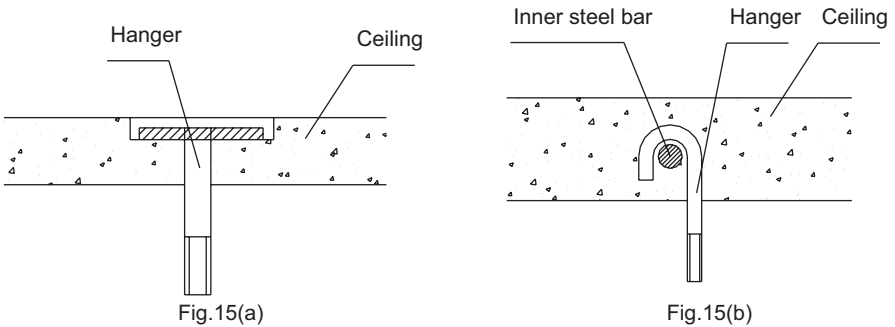

The damaged ceiling during installation of hanger should be repaired and recovered before completion of the project.

5.2.2 Installation Sketch of 80RV Series Energy Recovery Ventilation System

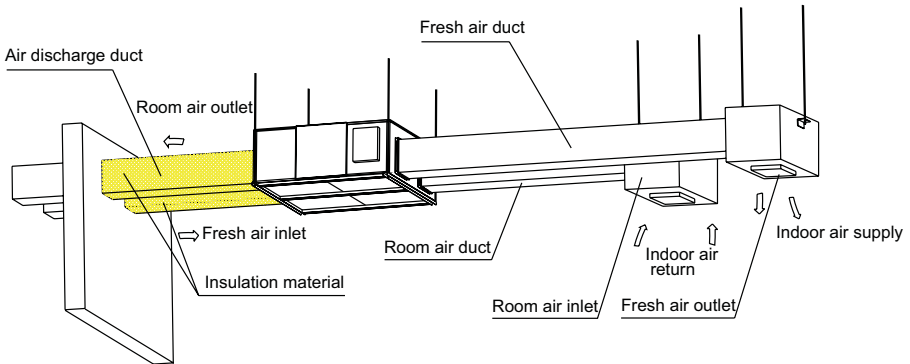

Fig.16 Installation Sketch of 80RV

During installation, the two ducts (fresh air inlet and room air outlet) outside the room must be installed with anti-condensate and heat insulating materials, and the ones inside the room should also be installed with them if temperature and humidity in the ceiling is high. The ducts outside the room should be kept inclined 1/50~1/30 to avoid water into the room.

Do keep service space for maintenance and cleaning of the filter and heat exchanger core in the system, as shown in Fig.17.

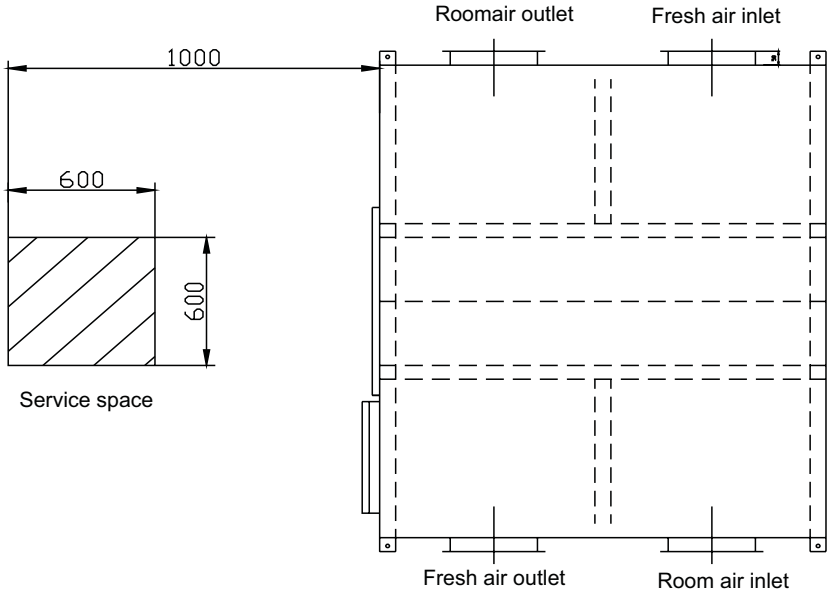

Fig.17 Sketch of Service Space

5.3 Project Construction

5.3.1 Installation of Wired Controller

(1) Locate the installation position firstly, and then reserve a groove or hole for embedding of communication wire according to its dimension.

(2) If wired controller and indoor communication wire are mounted visibly, 1 # PVC pipe can be used and corresponding grooves should be set in the wall (fig.18).If in hidden, 1 # PVC pipe can be used (as shown in fig.19).

(3) Whether mounted visibly or in hidden, drill two holes (keep level) in the wall as the distance(60mm)between the two holes in underplate of wired controller, and then inset stopper into the holes through which the wired controller can be fixed. Insert communication wire in the control board. At last, clasp the controller panel.

Note:

During installation of underplate of wired controller, pay attention to its direction. The side with 2 breaches must be kept downwards.

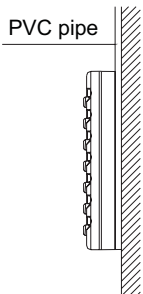

Fig.18

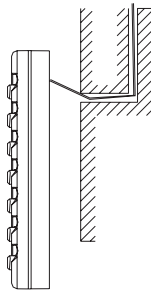

Fig.19

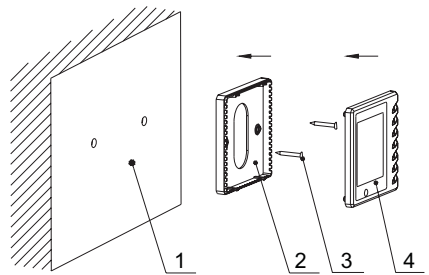

Fig.20

| No. | Name | Remarks |
|-----|-------------------------------|---|
| 1 | Wall | The appearance of the controller should be subject to entity. |
| 2 | Underplate of wire controller | |
| 3 | Screw M4X10 | |
| 4 | Controller panel | |

5.3.2 Manufacture of Duct and Parts

(1) The plates or sectional material used for manufacture should have factory certificate of qualification or quality identification document.

(2) The thickness of steel plate for manufacturing duct should accord with requirements in drawing.

(3) The surface of galvanized steel metal should be free of crack, scar and watermark but crystal texture.

(4) The specification and dimension of duct must accord with design requirements.

(5) The joint of duct must be tight and free of defects like crack etc.

(6) The surface of carbon steel should be coated with anticorrosion paint evenly and compactly.

(7) The allowable deviation to duct and flange is as follow:

Allowable deviation to manufacture of duct and flange

| No. | Item | Allowable deviation mm | Check Method |
|-----|--|----------------------------|--|
| 1 | External diameter of round duct. | $\varphi \leq 30\text{mm}$ | Diameters form 90° measured by ruler. |
| | | $\varphi > 300\text{mm}$ | |
| 2 | The longer edge of rectangle duct. | $\leq 300\text{mm}$ | Check by ruler. |
| | | $> 300\text{mm}$ | |
| 3 | Diameter of round flange | +2 0 | Diameters form 90° measured by ruler. |
| 4 | Diameter of rectangle flange. | +2 0 | Check by ruler. |
| 5 | Difference between diagonal lines of rectangle flange. | 3 | Check by ruler. |
| 6 | Planeness of flange. | 2 | Put them on the platform to check with feeler. |
| 7 | Planeness of weld joints of flange. | 1 | |

(8) The absolute value of difference between diagonal lines of rectangle flange should be $|L1-L2| \leq 3$, as shown in fig.21.

(9) The verticality tolerance between the flanges at two ends of the elbow of rectangle flange should be 3.0(90° elbow), and the absolute value of difference between diagonal lines should be $|L1-L2| \leq 3$, as shown in fig.22.

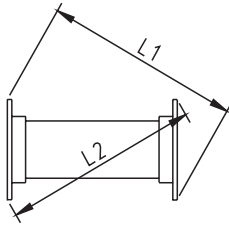

Fig.21 Rectangle duct

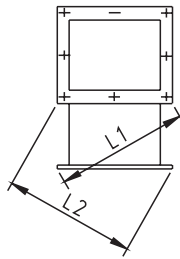
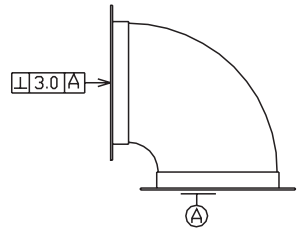

Fig.22 Elbow



5.4 Field Construction

(1) Never lay wires, cables and pipes with toxic, inflammable or explosive gas or liquid in the duct.

(2) The dismantable ports and adjustable parts of duct and fittings can not be installed in the wall or floor slab.

(3) The sundries and filth in or on the duct and fittings should be cleaned before installation.

(4) The construction of bracket or hanger of the duct should accord with the following specifications:

1) The build-in fitting, setting nail or expansion bolt for bracket or hanger should be placed correctly and firmly .The inlet part should be free of oil soil and painting.

2) The layout of the bracket or hanger should accord with design specifications. If there is no design specification, following specifications will apply.

a. Pole bracket or inclined bracket is applicable for horizontal duct against wall or pole and support bracket for that far from wall or pole. Strip hanger is applicable for the duct with diameter or length of side below 400mm.

b. Arm bracket or inclined bracket is applicable for vertical duct against wall or pole and hoop bracket for that far from wall or pole .The vertical pipe outside the room or on the roof should be fixed with derrick or dragline.

3) The hanger's rod should be flat and its screw thread should be full and smooth. Either threaded connection or welding is suitable for joint of hangers. If the former one is adopted, connecting thread of either end should be longer than diameter of hanger; moreover, anti-loosing measure should be made. If the later one is adopted, lapping joint is applicable and its length should be 6 times longer than diameter of hanger at least at two sides.

4) The holes on the bracket and hanger should be drilled mechanically and not with gas cutting.

5) Hoop bracket for rectangle duct should be appressed to the duct. Break angle should be flat. The distance for tightening of bolt should be kept at connecting place. Hoop arc for round duct should be uniform and its external diameter should accord with that of duct. Hoop should hold the duct as much as possible.

(5) The bracket and hanger can not be set at air vent, valve or service door. The hanger can not be directly fixed at flange. The distance between horizontal duct bracket and hanger can not exceed 4m.If the duct is installed vertically, the distance between them should not exceed 4m and the built-in fittings of each vertical duct should be more than 2 pieces.

(6) The duct flange, hanger and hanger for equipment should be coated with anticorrosion paint.

(7) The floor plate and wall which the duct passes should be repaired after construction. The holes on the external wall should be kept 2/100 gradient at level direction (the internal is higher) to avoid rainwater into the room.

(8) Installation of duct and connection between air vent and duct should be firm. The frame and decorative surface should be solid, external surface should be level and in deformable and adjustment should be flexible.

6 Electric Project

External wiring figure of the unit(If this one is different from wiring figure of junction box, take the wiring box of junction box as standard).

Suitable for 80RV030N20; 80RV050N20; 80RV060N20.

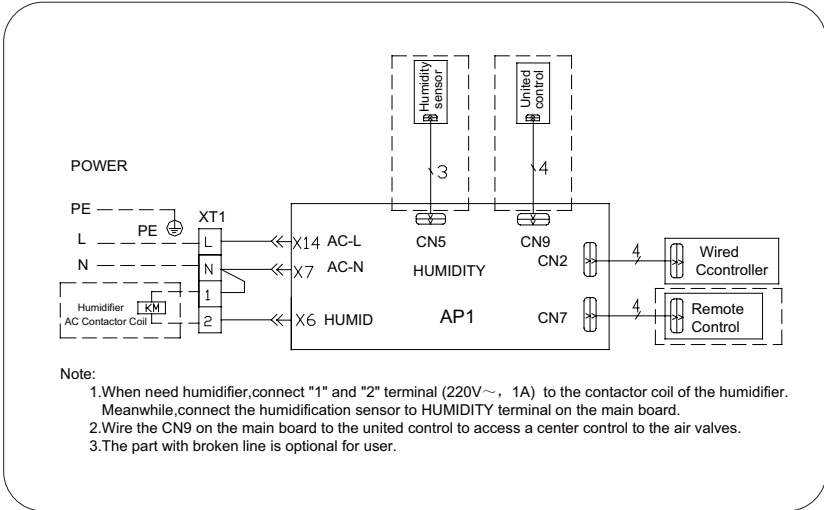

Fig.23 Wiring figure

Suitable for 80RV090N20.

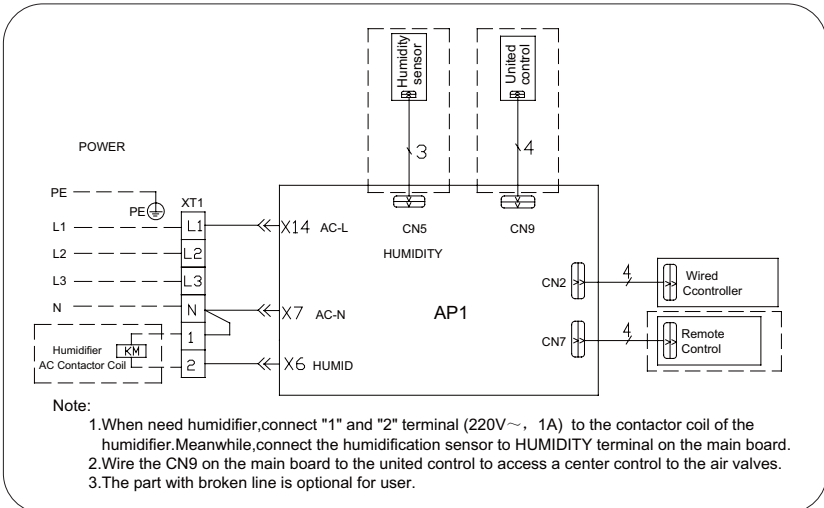

Fig.24 Wiring figure

7 Electric Installatrion

Notice: The AC must be reliably earthed to avoid electric shock or fire.

Layout of Wires

- (1) Layout of wires should accord with national wiring criteria.
- (2) The power supply must be with rated voltage and special for AC.
- (3) The power supply should be reliable to prevent terminals from being stressed. Never pull the power cord forcibly.
- (4) The line width of power cord must be large enough. Replace the broken power cord or connecting wire with special cable.
- (5) All of the electric installation must be performed by professionals according to local laws and regulations and instructions.
- (6) The earthing wire should be reliably connected with special earthing device and be performs by professionals.
- (7) Air switch and leakage switch which can cut off the general power supply should be installed.
- (8) The air switch should integrate the functions of magnetic release and hot release to protect it for short circuit or overload.
- (9) The field wiring should be subject to circuit diagram attached on the unit.

Recommended Air Switch and Power Cord

| Applied models | Power supply | Capacity of air switch(A) | Min. sectional area of earthing wire (mm ²) | Min. sectional area of power cord (mm ²) |
|----------------|----------------|---------------------------|---|--|
| 80RV030N20 | 208V~230V 60Hz | 6 | 1.0 | 1.0 |
| 80RV050N20 | 208V~230V 60Hz | 6 | 1.0 | 1.0 |
| 80RV060N20 | 208V~230V 60Hz | 6 | 1.0 | 1.0 |
| 80RV090N20 | 208V~230V 60Hz | 6 | 1.0 | 1.0 |

Note:

- ① . The power cord of the unit must be copper cored cable, and working temp can not exceed specified value.
- ② . Increase the sectional area of power cord above 15 meters to avoid overload.

Earthing Requirements

- (1) Reliable earthing measure must be adopted. The yellow green earthing wire with the only use never can be cut off and fixed with tapping screws to avoid electric shock.
- (2) Earthing resistance should be accord with national criteria GB17790.
- (3) Power supply must be reliably earthed. The earthing wire can not connect with:
 - ① . Tap water pipe;
 - ② . Gas pipe;
 - ③ . Blowing tube;
 - ④ . Place which specialist considers unreliable.

Warning:

- ① . Cut off the power supply before installation and maintenance to avoid electric shock.
- ② . Arrange wirings according to requirements strictly to avoid malfunction, electric shock or fire.

Special Notice:

The company won't be responsible for bad results because users self-modify the electric control system without consent of the company.

8 Operation and Maintenance

Check the connecting wires and perform trial run after installation work.

Check before trial run.

(1) Check of pipeline system

According to design drawing and instruction check bearings of duct, firmness of hanging of the equipment, anticorrosion paint of hanger and the said items which should be paid attention to as well as operation space for replacement of air filter, installation location of duct muffler, the inside or top of the duct or equipment for sundries or mounting tool and firmness of installation of duct vent.

(2) Check of circuit system

According to circuit diagram, check the connection and voltage of power cords.

Trial Run

(1) Power the unit on to start the unit. Refer to the section of instruction to operation of wired controller.

(2) If there is any malfunction, cut off the power supply and refer to fault diagnosis and check.

Daily Maintenance

Air filter must be installed, if not, heat exchange core will be covered with feculence and dust so that its performance will be reduced. If airflow volume or discharge air volume is obviously decreased, filter should be replaced for overmany dust. Setting of replacement period may be displayed in the displayer or according to actual condition in each area.



Fault Diagnose

After debugging and trial run, the unit can be normally used by the user. If any fault occurs, remove it firstly by yourself according to the following table before you contact us.



| Phenomenon | Possible causes | Solutions |
|---|--|--|
| Airflow volume at air outlet/inlet is obviously decreased after a period of time. | Too much dust gathers on the air filter. | Replace or clean air filter. |
| Noise occurs at air vent. | Installation of air vent is loose. | Re-fix the collecting place of air vent. |
| The system can not be started. | No power supply or missing phase Fuse burns out or circuit breaker trips. | Resume the power supply Replace fuse. |

9 Notice for Safety

- (1) Before installation, please carefully read Notice for Safety.
- (2) Be sure to conform to the following items to prevent damage to users or others.
The damage and degrees resulted from incorrect operation are as follow:

| | |
|---|---|
|  Danger | This mark means that dangerous cases like death or grievous harm will happen. |
|  Warning | This mark means that dangerous cases like death or grievous harm may happen. |
|  Notice | This mark means that injury or damage to property may happen. |

The contents to be conformed are defined as follows.

| | |
|---|--|
|  | This mark means "can't" or "prohibit". |
|  | These marks means "must" or "force" . |

Warning

- Please ask professionals for installation. Never install, move or refit the unit by yourself.



Forbid

Improper operation will cause falling, electric shock, fire and so on.

- Install the unit strictly according to the instruction.



Dangerous

Improper operation will cause electric shock, fire and so on.

- The electric project should be constructed according to national rules and construction instruction.



Dangerous

Poor capacity of power cord or improper construction will cause electric shock, fire and so on.

- Install bird net and suchlike things at air exchange vent.



Notice

Clean up sundries like nest to avoid deficiency of oxygen in the room.

- The air inlet should be installed at the place far from exhaust vent for fuel gas.



Dangerous

It's easy to cause deficiency of oxygen in the room.

- Install the air inlet at the place where exhausted air can not flow backwards.



Force

It's easy to cause pollution of the room and damage the health.

- The unit should be installed at the place with enough strength and reliability.



Notice

Some places are not strong enough for structure of the buildings.

- The earthing wire can not connect with gas pipe, water pipe, lightning rod, phone line and so on.



Dangerous

Improper earthing will cause electric shock.

- Turn off the switch and special circuit breaker during maintenance of the unit.



Dangerous

It's easy to cause electric shock.

Notice

- Do not put the burning appliances at the place against the airvent.



It is easy to cause insufficient burning of the burning appliances.
If water leaks, it will enter into the unit and damage electrical insulator.

Forbid

- Take waterproof measures for the unit.



If water leaks, it will enter into the unit and damage electrical insulator and cause electric shock.

Dangerous

- Do not use flammable sprayer near the main unit.



It is easy to cause fire.

Forbid

- Operate the switch correctly. Never quickly repeat.



It is easy to cause incorrect operation and result in bad effect to switch and internal relay.

Notice

- Never wash the main unit with.



It is easy to cause electric shock.

Dangerous

- Never operate the switch with wet hand.



It is easy to cause electric shock.

Forbid

- Periodically clean the filter.



Too much dust attached on the filter will cause hypoxia in the room.

Notice

- Wear gloves to clean filter and heat exchanger.



It is easy to cause injury.

Notice

- Turn off the breaker if the unit will not be in use for a long time to ensure safety.



Too much dust will heat and cause fire.

Notice

- Do not install the unit at the wet place like bathroom, etc.



Too much dust attached on the filter will cause hypoxia in the room.

Forbid

- Do not install the unit against fire source or at the place where there is naked flame.



It is easy to cause heat or fire.

Forbid

- Do not install the unit at the place where there is leakage of flammable gas.



If there is leaked gas around the unit, fire is easy to result.

Forbid

- Do not install the unit at the place where there is acid, alkaline, organic solvent, paint and other harmful or corrosive gas, like chemical plant, etc.



It is easy to cause poisoning and fire.

Forbid

- Maintenance space must be reserved. (maintenance place)



It is convenient to clean heat exchanger core and filter and maintain the equipment.

Notice

Warning

- Never insert finger or stick into suction or discharge vent.



Forbid

It is easy to cause injury that the fan runs at high speed.

- Ventilate the room by opening the window if flammable gas leaks.



Danger

The spark electric contact may cause explosion or fire after the unit starts.

- Never refit ,disassemble or repair the unit by yourself.



Forbid

Improper repair may cause electric shock or fire.

- Use the unit according to rated voltage.



Forbid

It is easy to cause electric shock or fire.

- Stop the unit and turn off special breaker once particular smell occurs.



Danger

Continuous operation in abnormal state may cause malfunction ,electric shock or fire.

- Never put animals or plants against air vent.



Notice

It may cause bad effect to animals and plants.

- Make insulated layer between pipe and wall if metal pipe goes through metal sheet or mesh of wooden building



Must

It is easy to cause electric shock or leakage.

Danger

- Open system burning equipments (warm air) for air exchange can not be used.



Forbid

If gas or oil heater is used in the room, special ventilation equipment must be used.

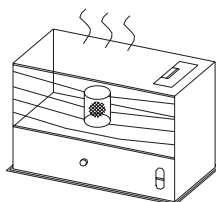

Model and Technical Specifications

● Specifications of slim ducted type indoor unit

| Model | 80RV020N20 | 80RV030N20 | 80RV050N20 |
|---|---------------------------|---------------------|---------------------|
| Fuction | Cooling and Heating | Cooling and Heating | Cooling and Heating |
| Airflow Rate (m ³ h/CFM) | 360/212 | 500/294 | 800/471 |
| Sound Level (dB (A)) | 37 | 39 | 45 |
| Input of Motor (KW) | 0.165 | 0.262 | 0.4 |
| External Statics Press (Pa) | 80 | 80 | 85 |
| Temperature Exchange Efficiency(%) | 73 | 70 | 72 |
| Enthalpy Exchange Efficiency Cooling(%) | 63 | 59 | 62 |
| Enthalpy Exchange Efficiency Heating(%) | 67 | 64 | 65 |
| Power Supply | 208-230V / 1 phase / 60Hz | | |
| Dimension(W×D×H)(mm) | 800X879X306 | 800X879X306 | 832X1016X380 |
| Net Weight(kg) | 45 | 45 | 57 |

| Model | 80RV060N20 | 80RV090N20 |
|---|---------------------|----------------------|
| Fuction | Cooling and Heating | Cooling and Heating |
| Airflow Rate (m ³ h/CFM) | 1000/588 | 1500/882 |
| Sound Level (dB (A)) | 46 | 48 |
| Input of Motor (KW) | 0.44 | 0.6 |
| External Statics Press (Pa) | 85 | 150 |
| Temperature Exchange Efficiency(%) | 77 | 73 |
| Enthalpy Exchange Efficiency Cooling(%) | 64 | 60 |
| Enthalpy Exchange Efficiency Heating(%) | 68 | 5 |
| Power Supply | 208-230V/1phase/60H | 208-230V/3phase/60Hz |
| Dimension(W×D×H)(mm) | 832X1016X380 | 1210X1215X452 |
| Net Weight(kg) | 57 | 100 |

☆ The above performance parameter is measured according to the standard of GB/T18837-2002, and its cooling or heating capacity and sound level are tested before leaving factory.

If the parameter changed, refer to the data offered on nameplate.

Thank you for Choosing



www.delta-dct.com



66129916179